

# TRETEL

## ELECTRO-PERMANENT TELESCOPIC BEAM

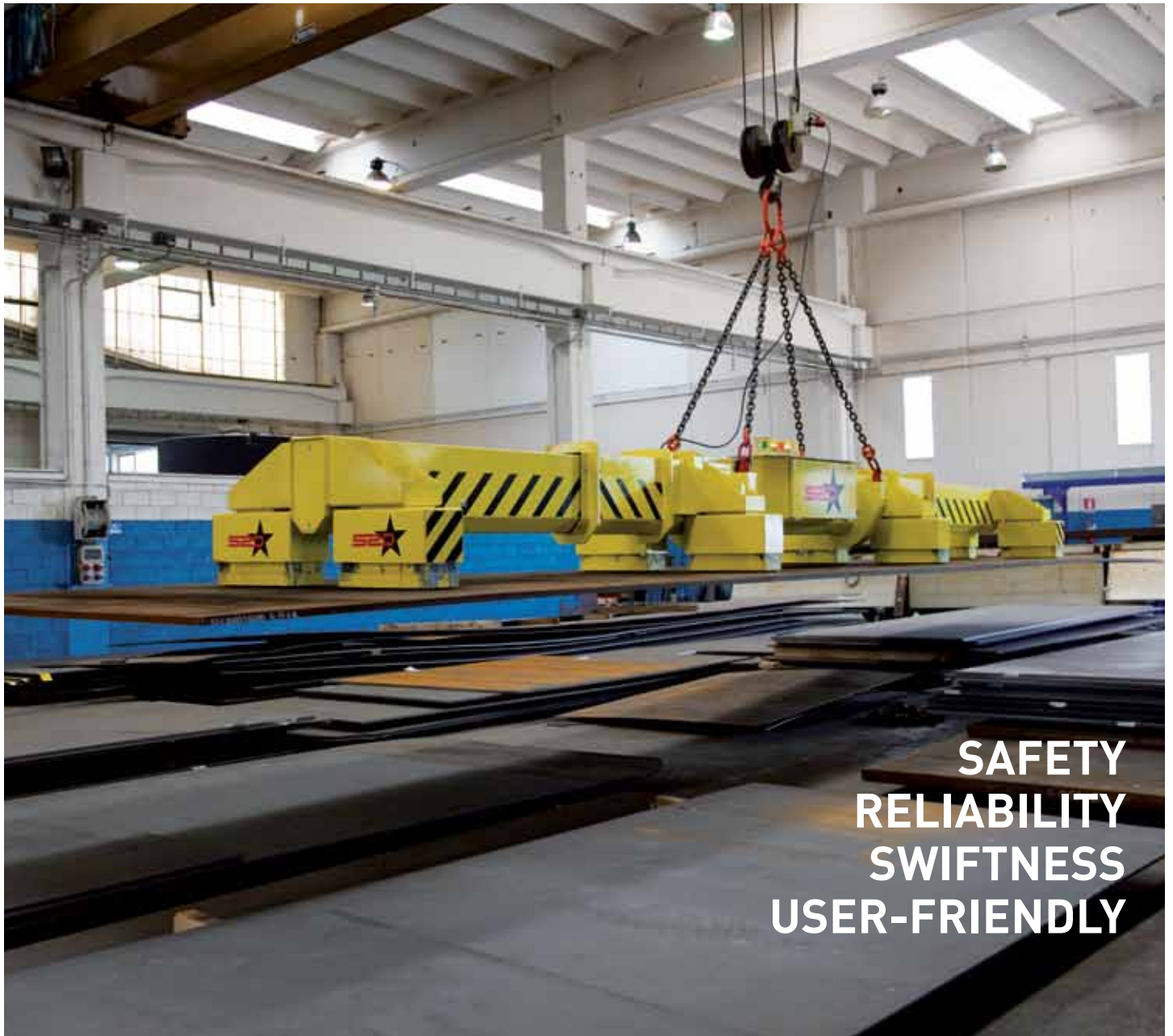

## ELECTRO-PERMANENT MAGNETIC LIFTING SYSTEMS



## ADVANTAGES OF THE ELECTRO-PERMANENT SYSTEM

The electro-permanent magnetic lifter guarantees absolute safety even in case of power failures.

It doesn't require any backup batteries. The load remains anchored to the lifter for an unlimited time without any alteration of the clamping force. This system is furthermore energy-saving as it requires the power supply only during the MAG and DEMAG cycles.

With the beams of the **TRETEL**-series it is possible to shift large-sized sheets of any width, by lifting the load from the top without being deformed or damaged. The transfer is thus safely and smoothly performed, reducing both handling and sheet storage time.

The telescopic beam features extendable arms controlled by a hydraulic pump and offers the possibility to select the modules to be magnetized, depending on the dimensions of the load to be lifted, in 4 different operating modes:

1. Sheets ranging from 3m to 5 m: just the intermediate modules
2. from 6m to 12 m: all the modules
3. Straps: only the modules on the left-hand side
4. Straps: only the modules on the right-hand side

By means of the radio control included in the standard supply one single user is able to carry out every operation (anchoring, lifting, handling, release, extension and retraction of the telescopic arms)

by keeping the necessary safety distance from the load. There is furthermore an optimization of the working area as no additional side clearance for the sheet handling is required.

## RADIO CONTROL

1. The radio control allows to carry out at a safe distance any control operation (Pick-Up, Full Mag, Demag, Safe, Open, Close).
2. It features a Start and an Emergency Stop push-button.
3. Adjustable frequency.
4. Equipped with a battery charger and rechargeable batteries.

## SAFETY-SYSTEM AGAINST AN UNINTENTIONAL DEACTIVATION

Double proximity sensor in order to avoid an unintentional demagnetization with lifted load. This operation can only be carried out with both slackened chains and load resting on the ground.

A special safety system enables the extension or retraction of the telescopic arms only with previously demagnetized modules and stretched hoist chains.

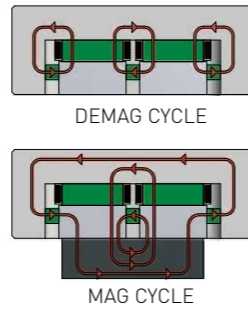

PERFORMANCE GRAPH MAGNETIC FORCE - AIR GAP

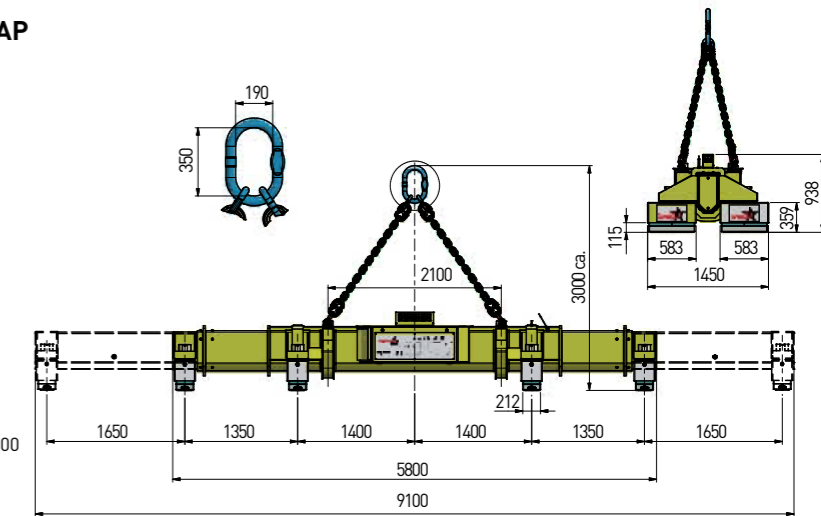
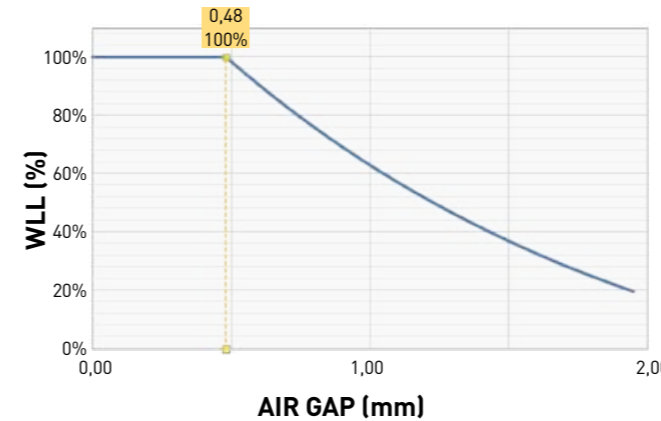

TECHNICAL FEATURES OF THE TELESCOPIC BEAMS "TRETEL"

Beam type	Lifting capacity (kg)	Minimum thickness (mm)	Length of the sheet to be lifted		Width of the sheet to be lifted		Dimensions of the liftable straps with half of the modules		Maximum beam overall dimensions			Beam weight (kg)
			Minimum (mm)	Maximum (mm)	Minimum (mm)	Maximum (mm)	Minimum (mm)	Maximum (mm)	Width (mm)	Length (mm) closed/open	Total Height stretched hoisting chains included (mm)	
TRETEL - 408	8.000	5	3.000	12.000	1.400	3.500	500	1.200	1.450	5.800/9.100	2.700	2.500
TRETEL - 410	10.000											
TRETEL - 412	12.500											
TRETEL - 415	15.000	8	2.800	16.000	1.400	3.500	500	1.200	1.450	9.800/13.100	3.700	3.600
TRETEL - 418	18.000											
TRETEL - 610	10.000	5	2.800	16.000	1.400	3.500	500	1.200	1.450	9.800/13.100	3.700	3.600
TRETEL - 614	14.000											
TRETEL - 618	18.000	8	2.800	16.000	1.400	3.500	500	1.200	1.450	9.800/13.100	3.700	3.600
TRETEL - 622	22.000											
TRETEL - 627	27.000											

## MANUALLY OPERATED LIFTERS



Sturdy, handy and powerful neodymium magnetic lifters activated by lever.

Suitable for the handling of ferrous loads in various fields of application (loading and unloading on machine tools, oxycutting, warehouses, mechanical assembly, welding, etc.).

Suitable for the lifting of both flat and round loads.

## BATTERY-DRIVEN LIFTERS



Battery-driven electro-permanent magnetic lifter for payloads ranging from 500kg to 6000 kg.

Radio control for an operation at a proper safety distance.

Can be employed on any lifting equipment without having to be connected to an external power supply. Long-lasting operational autonomy, as the power supply is limited to the MAG and DEMAG cycle, only.

## SEP - LIFTERS



The well-structured SEP-modules, specially designed for the handling of slabs and forged blocks with an increased air-gap, are able to withstand high stresses and strains and are therefore extremely reliable over time.

By means of the radio control included in the standard supply one single user is able to carry out every operation (anchoring, lifting, handling, release) by keeping the necessary safety distance from the load.

## LIFTERS FOR COILS



Modules for the handling of compact coils of any size and weight.

Offers the advantage of not deforming or damaging the load, and of reducing the operating spaces, as the module is always positioned from above onto the coil.

Suitable for coils with horizontal or vertical axis.



**S.P.D. S.p.A.**

Via Galileo Galilei, 2/4  
24043 Caravaggio (BG) ITALY  
Tel. +39 0363 546 511  
Fax +39 0363 52578  
info@spd.it - [www.spd.it](http://www.spd.it)



TRETEL 12/2018