



# Robik Trolley F4K

**S\_RT-H20-125-175-F4K**

Modular trolleys for heavy loads handling

**SATES**  
**Robik**<sup>srl</sup>

# Technical Data Sheet

Last update: 10/03/2026

## General Specifications

Product name	Robik Trolley
Manufacturer	SATES & ROBIK S.R.L.
Description	Accessory trolley
Manufacturer code	S_RT-H20-125-175-F4K

## Frame Specifications

Frame material	Steel
Surface treatment	Cold galvanised coating
Special treatment (on request)	Cataphoresis coating + painting
Finish	Galvanized

## Performance Specifications

Maximum operating speed	2.0 km/h
Surface extension area	~520 mm
Load capacity on flat floor	± 4.000 kg ± 39.226,6N
Slope	Flat surface
Stopping distance during deceleration (without load) with adequate traction on flat ground	~2000mm

### THEORETICAL VALUES:

Average transportable load: 4 tons with medium–low friction coefficients and load evenly distributed on both support surfaces.

\* The transportable load depends on the slope, the type of surface and the duration of operation.

\*\*The transport capacity expressed in tons may vary significantly from the nominal value indicated here depending on several factors, including the type of surface on which the towing operation is performed, the presence of slopes and the friction present and generated by the system as a whole.

## Load Platform

Material	Resin-coated birch plywood panel
Maximum extension	~520 mm
Moisture content	max 80%

## Dimensions *(see technical drawings)*

Maximum length	1750 mm
Minimum length	1230 mm
Maximum width	500 mm
Minimum width	466 mm
Load platform height	204 mm
Wheelbase	210 mm
Weight*	± 70 kg

\* It may vary

## Standard Wheels

Total number of wheels	6 cast iron wheels
Fixed wheels technical material Shore A 92 High Flow	4 twin wheels
Swivel wheels technical material Shore A 92 High Flow	2 twin wheels
Drive wheel dimensions	125/50 x 2 twin
Steering wheel dimensions	125/50 x 2 twin

## Optional Wheels

Super-elastic fixed wheels	Available on request
Super-elastic swivel wheels	Available on request

IMPORTANT NOTE the specifications indicated may change over time; variants may also be introduced to improve the performance or further enhance Robik Trolley

# Technical Drawing

S\_RT-H20-125-175-F4K

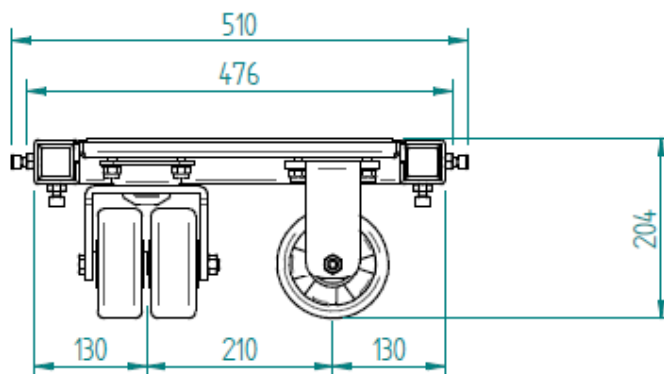
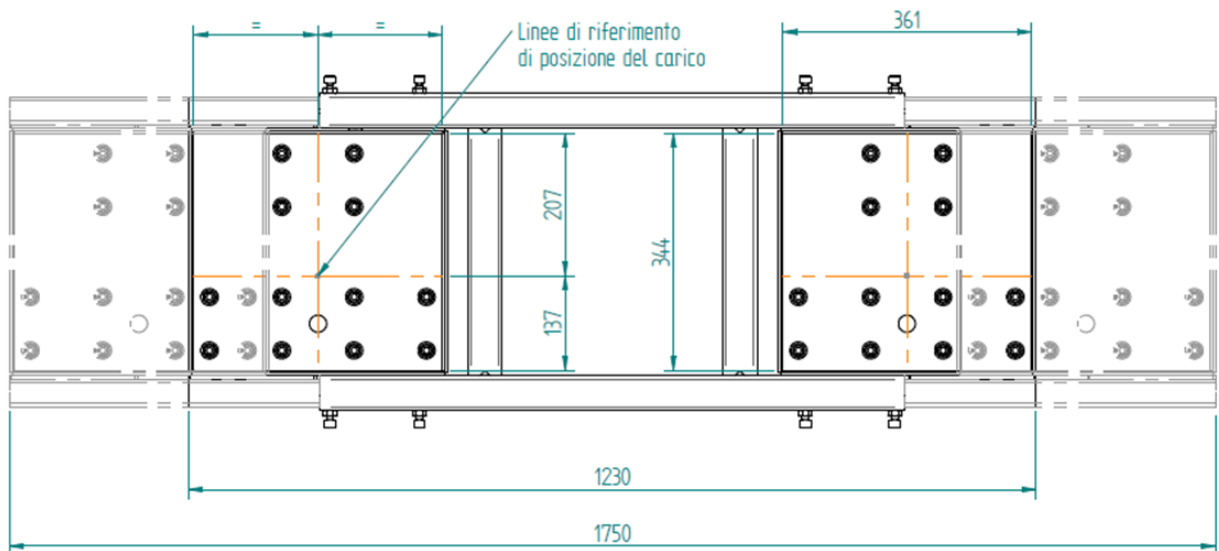
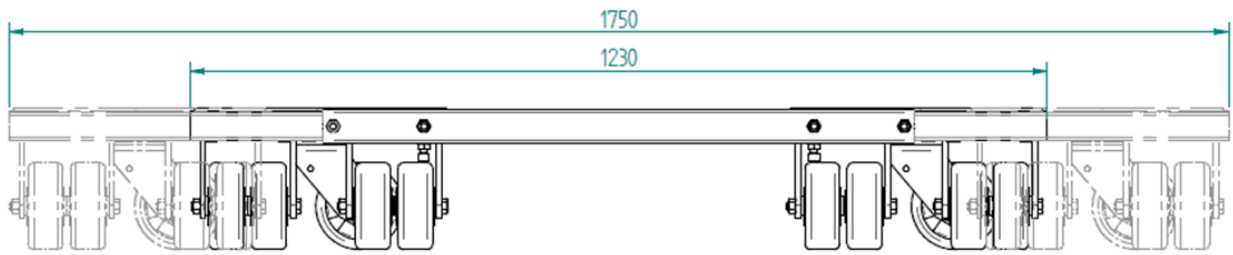

IMPORTANT NOTE dimensions may change without prior notice



SATES & ROBIK S.R.L.

Via dell'Artigianato, 36 - 35020 Casalserugo (PD) ITALY

TEL. +39 049 643487 - P.IVA e C.F. 05712940286 - SDI M5UXCR1

www.robik.it - supporto@robik.it